



**SUPER
MANIFOLD**
FOR A90/A91 SUPRA & BMW G-SERIES

WWW.CSF RACE.COM

CHARGE-AIR COOLER/INTAKE MANIFOLD



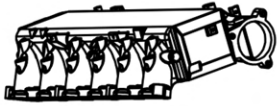

SERIAL NO. _____ QC _____ REV. 4.2 - 11/28/22

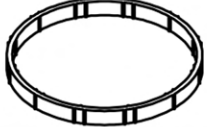
ID		QTY	DESCRIPTION	CSF #	NOTE
A		1	INTAKE MANIFOLD	8200 OR 8200C	

OEM PARTS (NOT SUPPLIED)





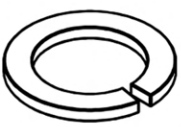
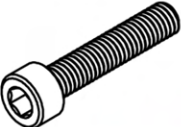



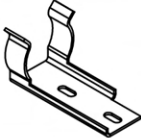
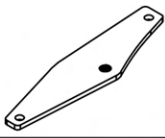
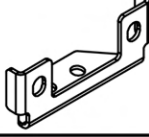

ID		QTY	DESCRIPTION	CSF #	NOTE
I		6	RUNNER O-RING (GREEN)	B58-G-1	[SEE DIAGRAM #1] INSTALL INTO INDIVIDUAL CYLINDER GROOVES ON BOTTOM OF MANIFOLD OUTLET TANK *INSPECT FOR DAMAGE BEFORE INSTALLATION BMW OEM #11618637800
V		1	THROTTLE BODY O-RING (RED)	B58-G-3	[SEE DIAGRAM #3] INSTALL ONTO THROTTLE BODY *INSPECT FOR DAMAGE BEFORE INSTALLATION BMW OEM #18548632344

BRACKETS & HARDWARE (KIT #1)

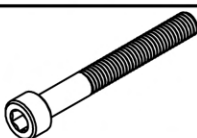
ID		QTY	DESCRIPTION	CSF #	NOTE
B		1	VACUUM LINE BRACKET #1 (SATIN BLACK POWDERCOAT)	B58-BR-1	[SEE DIAGRAM #4] ATTACHES TO INSIDE OF FUEL RAIL BRACKET ON OUTLET TANK OF MANIFOLD
E		5	M5 X 0.8 X 8 BHCS (CLEAR ZINC)	B58-B-1	
G		1	VACUUM LINE BRACKET #2 (SATIN BLACK POWDERCOAT)	B58-BR-2	[SEE DIAGRAM #4]
J		1	HARNESS BRACKET #3 (SATIN BLACK POWDERCOAT)	B58-BR-3	[SEE DIAGRAM #1 - FRONT OF MANIFOLD] USE QTY. 1 WASHER (K) USE QTY. 1 SCREW (AF)
K		7	M6 SPLIT LOCK WASHER (CLEAR ZINC)	B58-W-1	
L		7	M6 X 1.00 X 35 SHCS (CLEAR ZINC)	B58-B-8	[SEE DIAGRAM #1] MANIFOLD-TO-CYLINDER HEAD BOLT USE QTY. 7 WASHERS (K)

BRACKETS & HARDWARE CONT. (KIT #1)

REV. 4.2 - 11/28/22

ID		QTY	DESCRIPTION	CSF #	NOTE
N		1	HARNESS BRACKET #1 (SATIN BLACK POWDERCOAT)	B58-BR-4	(SEE DIAGRAM #3) USE QTY. 1 SCREW (AF) *TIGHT FIT ON 8200C
O		1	STAND-OFF #1 (BLACK ANODIZE)	B58-BR-5	(SEE DIAGRAM #3) OPTIONAL - FOR USE WITH ENGINE COVER INSTALLATION
P		1	STAND-OFF #2 (BLACK ANODIZE)	B58-BR-6	(SEE DIAGRAM #3) OPTIONAL - FOR USE WITH ENGINE COVER INSTALLATION INSTALLS ON TOP OF BRACKET (R), USE QTY. 1 SCREW (AF)
Q		1	VACUUM RESEVOIR BRACKET (SATIN BLACK POWDERCOAT)	B58-BR-7	(SEE DIAGRAM #3) INSTALLS UNDERNEATH OPTIONAL BRACKET (R) SLOTTED MOUNTING HOLES FOR ADJUSTABILITY
R		1	STAND-OFF (P) BRACKET (SATIN BLACK POWDERCOAT)	B58-BR-8	ORIENTATION SPECIFIC (SEE DIAGRAM #3) OPTIONAL - FOR USE WITH ENGINE COVER INSTALLATION USE WITH MOUNTING POST (P), QTY. 1 SCREW (E) & QTY. 1 SCREW (AE)
S		1	HARNESS BRACKET #2 (SATIN BLACK POWDERCOAT)	B58-BR-9	(SEE DIAGRAM #3)
T		11	STEEL 1/8" NPT BUNG (CLEAR ZINC)	B58-F-2	OPTIONAL PLUGS - RECOMMEND: SEALING TAPE OR GREASE (SEE DIAGRAM #2 - FOR NITROUS/METHANOL PORTS ON OUTLET TANK - QTY. 6) (SEE DIAGRAM #3 - FOR VACUUM PAD ON INLET TANK - QTY. 3, WATER BLEEDER PORTS ON REAR WATER TANK* - QTY. 2) *USE WITH THREAD SEALANT
W		3	M6 X 1.0 X 50 SHCS (CLEAR ZINC)	B58-B-4	(SEE DIAGRAM #3) USED TO BOLT THROTTLE BODY TO INLET TANK * REMINDER - USE QTY. 1 GASKET (V)
AG		1	EMISSION PORT CAP (BLACK ANODIZE)	B58-F-7	(SEE DIAGRAM #3) OPTIONAL USE QTY. 1 O-RING (AG), USE QTY. 1 SCREW (E)
AD		1	M6 X 1.00 X 16 BHCS (CLEAR ZINC)	B58-B-5	(SEE DIAGRAM #1) USED TO INSTALL MAP SENSOR ON OUTLET TANK INSTALL BEFORE BUILDING OPTIONAL FUEL SYSTEM ONTO MANIFOLD
AE		2	M5 X 0.8 X 12 BHCS (CLEAR ZINC)	B58-B-6	(SEE DIAGRAM #3) USED WITH BRACKET (R) (OPTIONAL FOR ENGINE COVER) USED WITH BRACKET (Q)
AF		3	M6 X 1.00 X 8 BHCS (CLEAR ZINC)	B58-B-7	(SEE DIAGRAM #1) USED WITH BRACKET (J) (SEE DIAGRAM #3) USED WITH BRACKET (N) & BRACKET (R) TO ATTACH POST (P)
AG		1	EMISSION PORT CAP O-RING (AG) (BLACK)	B58-G-4	(SEE DIAGRAM #3) OPTIONAL INSTALLS ON FITTING (AC)









THIS PRODUCT IS DESIGNED SOLELY FOR OFF-ROAD OR MOTORSPORTS USE.

WATER KIT (KIT #2)

REV. 4.2 - 11/28/22

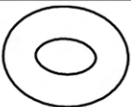
ID		QTY	DESCRIPTION	CSF #	NOTE
U		2	-10 ORB TO 3/4 HOSE (BLACK ANODIZE)	B58-F-3	(SEE DIAGRAM #3) REAR WATER TANK - INCLUDES PRE-INSTALLED O-RING (AM) TO SEAL
X		2	QUICK CONNECT (BLACK ANODIZE)	B58-F-4	(SEE DIAGRAM #3) USE WITH QTY. 2 CLAMPS (Z) ATTACHES TO QTY. 2 HOSES (Y)
Y		2	3/4" HEATER HOSE (RUBBER)	B58-H-1	(SEE DIAGRAM #3) USE WITH QTY. 4 CLAMPS (Z) ATTACHES TO QTY. 2 FITTINGS (X) ATTACHES TO QTY. 2 FITTINGS (U)
Z		4	WORM DRIVE HOSE CLAMP 14-27 (X) (STAINLESS STEEL)	B58-LOC-1	(SEE DIAGRAM #3) USE WITH QTY. 4 CLAMPS WITH QTY. 2 WATER HOSE (Y)
AI		2	CRANKCASE VENT HOSE O-RING REPLACEMENT (BLACK)	B58-G-5	(SEE DIAGRAM #6) REPLACE OEM O-RING USE QTY.1 O-RING - EXTRA INCLUDED AS SPARE
AM		4	-10 O-RING (BROWN)	B58-G-7	PRE-INSTALLED ON QTY. 4 WATER LINE HOSE BARB (U, AK, AJ)
AJ		1	-10 ORB CRANKCASE QUICK CONNECT HOSE FITTING (BLACK ANODIZE)	B58-F7	(SEE DIAGRAM #1) CRANKCASE - INCLUDES PRE-INSTALLED O-RING (AM) TO SEAL
AK		1	-10 ORB CRANKCASE BUNG FITTING (BLACK ANODIZE)	B58-F8	(SEE DIAGRAM #1) CRANKCASE - INCLUDES PRE-INSTALLED O-RING (AM) TO SEAL

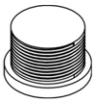
FUEL KIT (OPTIONAL) (KIT #3)

ID		QTY	DESCRIPTION	CSF #	NOTE
C		1	FUEL RAIL	8200F	(SEE DIAGRAM #4)
D		2	NYLOC NUT M5 X 0.8 (CLEAR ZINC)	B58-N-1	(SEE DIAGRAM #4)
F		6	INJECTOR PORT BUNG (BLACK ANODIZE)	B58-F-1	(SEE DIAGRAM #2) USE WITH QTY. 6 O-RING (M) (PRE-INSTALLED) *RETURN BACK TO CSF FOR LIMITED EDITION SHIRT IF NOT IN USE
H	 	2 + 1	M5 X 0.8 X 30MM BHCS (CLEAR ZINC) M5 X 0.8 X 12MM BHCS (CLEAR ZINC)	B58-B-2	(SEE DIAGRAM #4) USE 30MM WITH FUEL RAIL USE 12MM WITHOUT FUEL RAIL
M		6	INJECTOR PORT BUNG O-RING (BLACK)	B58-G-2	PRE-INSTALLED ON QTY. 6 INJECTOR HAT (AA) & QTY. 6 INJECTOR PORT BUNG (F)
AA		6	INJECTOR HAT (BLACK ANODIZE)	B58-F-5	(SEE DIAGRAM #5) COMES WITH QTY. 6 INJECTOR LOCKING CLIP
AB		1	-8 INTERNAL HEX PLUG (BLACK ANODIZE)	B58-F-6	(SEE DIAGRAM #4) OPTIONAL - INCLUDES PRE-INSTALLED O-RING TO SEAL ATTACHES TO FUEL RAIL (C) FOR USE ON VEHICLES WITHOUT A SECONDARY FUEL SYSTEM RETURN
AL		1	-8 INTERNAML HEX PLUG O-RING (BROWN)	B58-G-5	PRE-INSTALLED ON QTY.1 -8 HEX PLUG (AB)

THIS PRODUCT IS DESIGNED SOLELY FOR OFF-ROAD OR MOTORSPORTS USE.

DIAGRAM #1

REV. 4.2 - 11/28/22

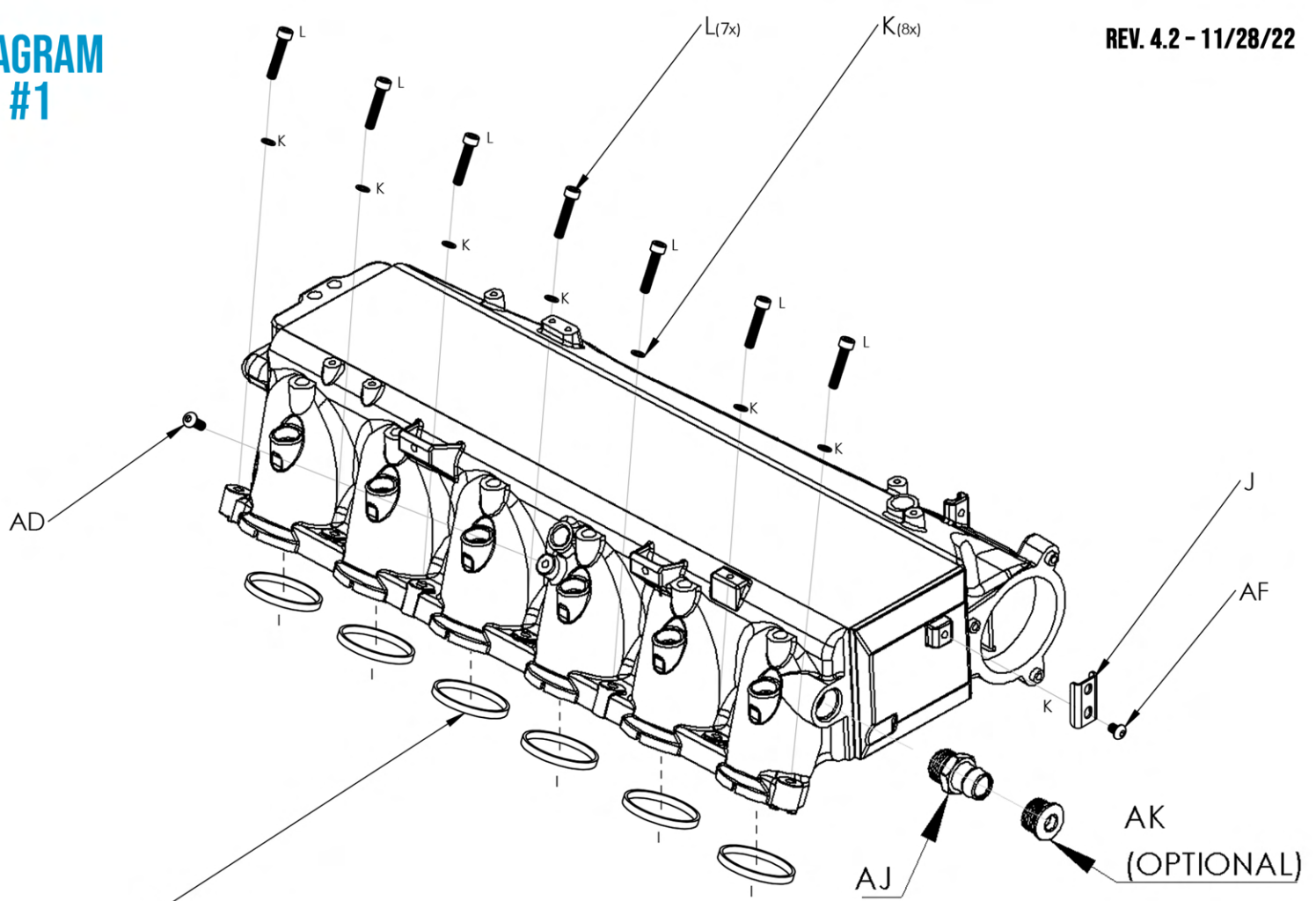
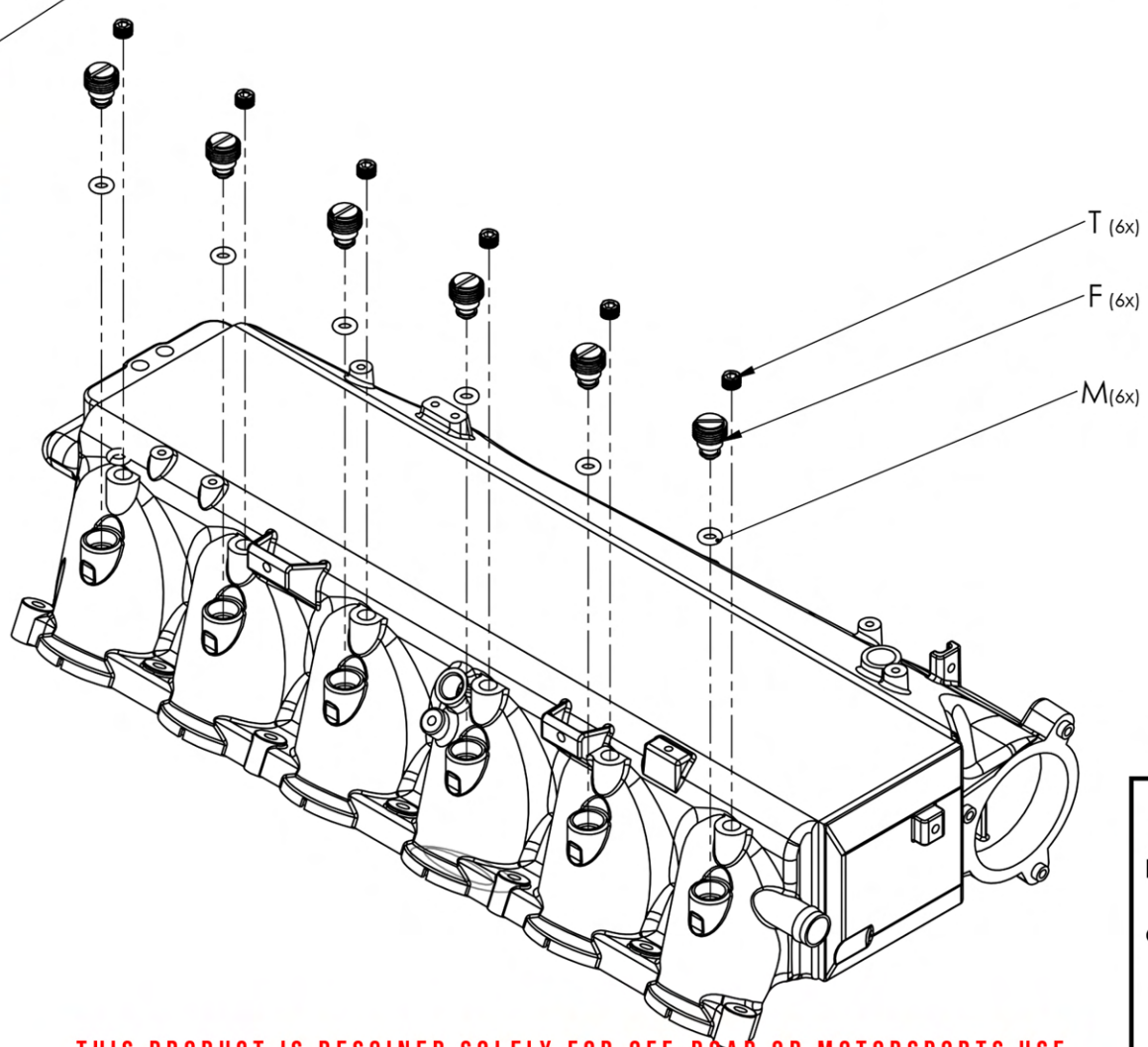

DIAGRAM #2



PLEASE REFER TO PARTS LIST FOR REFERENCE.

CSF, INC.
RACING & HIGH-PERFORMANCE

COO x **CSF** x **VF**
CHARGE-AIR COOLER
MANIFOLD
FOR A90/91 SUPRA &
BMW B58

THIS PRODUCT IS DESIGNED SOLELY FOR OFF-ROAD OR MOTORSPORTS USE.

DIAGRAM #3

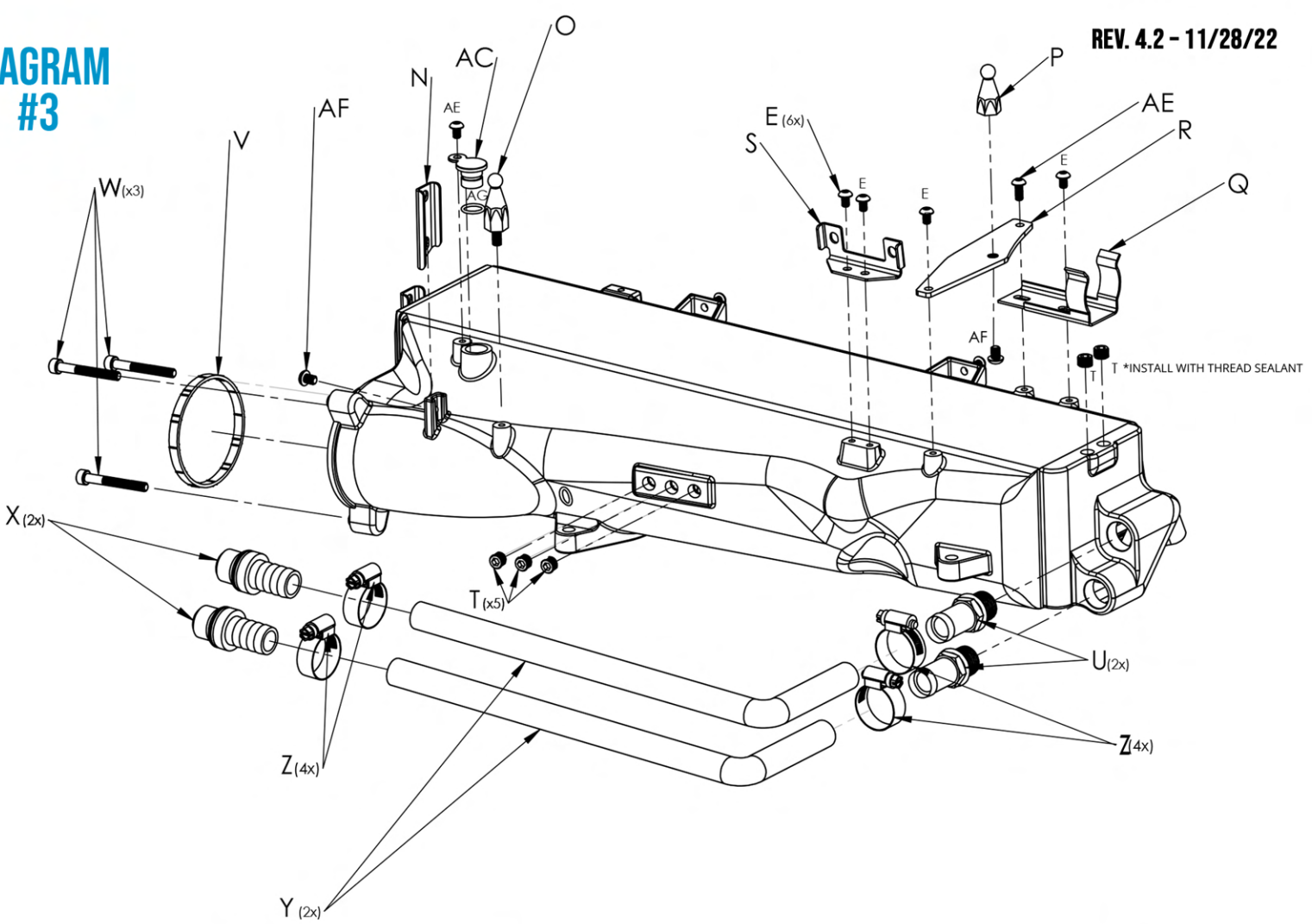
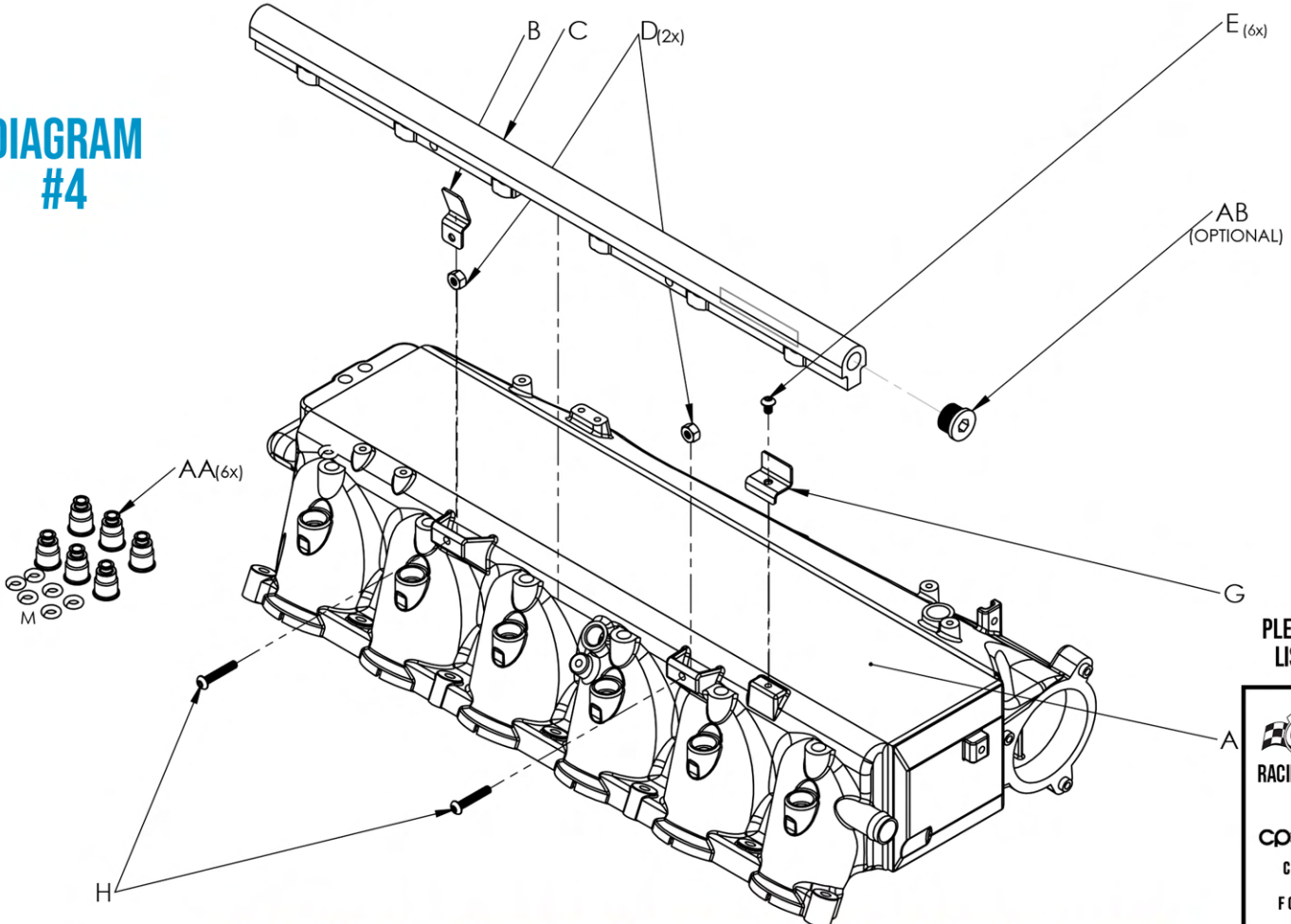

DIAGRAM #4



PLEASE REFER TO PARTS LIST FOR REFERENCE.

CSF, INC.
RACING & HIGH-PERFORMANCE

COO x **CSF** x **VF**
CHARGE-AIR COOLER
MANIFOLD
FOR A90/91 SUPRA &
BMW B58

THIS PRODUCT IS DESIGNED SOLELY FOR OFF-ROAD OR MOTORSPORTS USE.

**DIAGRAM
#5**

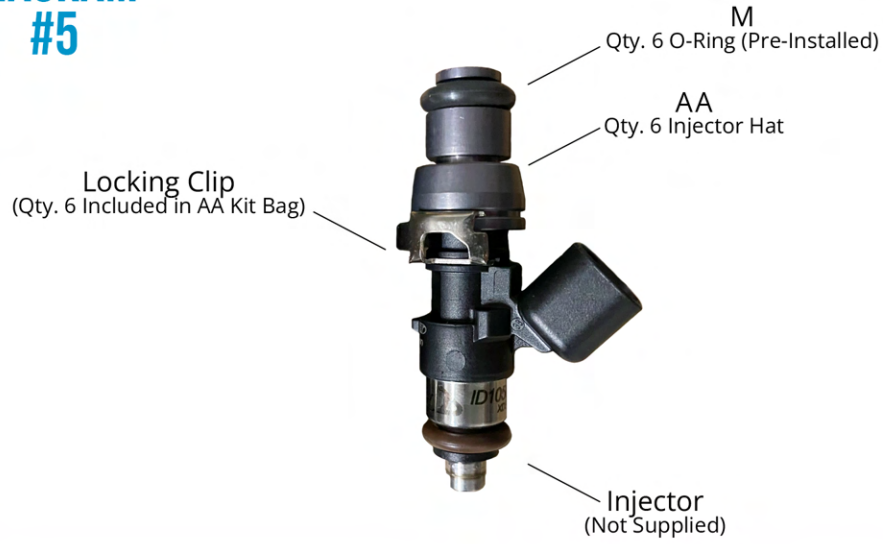

**DIAGRAM
#6**

Remove OEM O-Ring from crankcase vent tube
- Suggest to use pick to remove O-Ring

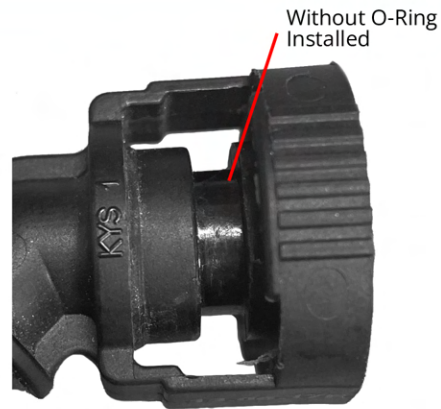

Replace with Qty.1 CSF supplied O-Ring (AI)
- If having difficulty installing O-Ring, use lubrication



INSTRUCTIONS

CSF #8200 - B58 MANIFOLD

PLEASE FOLLOW THESE INSTRUCTIONS CAREFULLY IN THE CORRECT SEQUENCE

ENGINE COVER WILL NOT FIT IF THE FUEL RAIL IS INSTALLED

CSF RECOMMENDS UNSTAPLING THIS INSTRUCTION PACKET AND LAYING IT OUT IN NUMERICAL ORDER

1. Inspect and reinstall OEM gaskets to cylinder runners on the outlet side of the manifold (green color) and throttle body flange (red color) (See Diagram #1)
 - Qty. 6 gasket (I) (green color)
 - Qty. 1 gasket (V) (red color)
2. Connect throttle body to manifold (See Diagram #3)
 - Qty. 3 bolt (W)
3. Connect coolant lines to manifold (suggest to use Loctite, thread sealant, or sealing grease as a precaution) (See Diagram #3)
 - Qty. 2 hose fittings (U)
 - Qty. 2 hoses (Y)
 - Qty. 2 clamps (Z)
 - Cut down hoses to desired length (see photo #1)
 - Please make sure to leave enough slack in the hoses to clear oil filter housing (see photo #2)
 - Use supplied hardware and fittings to connect to OEM quick-connect system (see photo #3)
 - OEM water lines are located under the manifold, please move off to the right side (inlet tank side) of the manifold for easy access before continuing to step
 - Qty. 2 Quick-Connect fittings (X)
 - Qty. 2 clamps (Z)



Suggested cut measurement approx. 4" from inside radius for top fitting/approx. 3" for bottom fitting

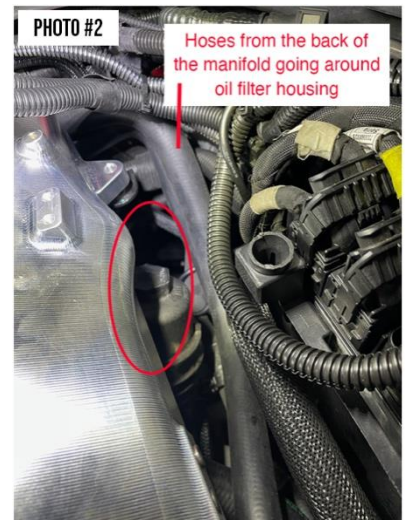

Continued on Next Page

- For proper routing of water lines (see photo #4) and note top line (Blue) is inlet from water pump, lower line (Red) is outlet to heat exchanger.

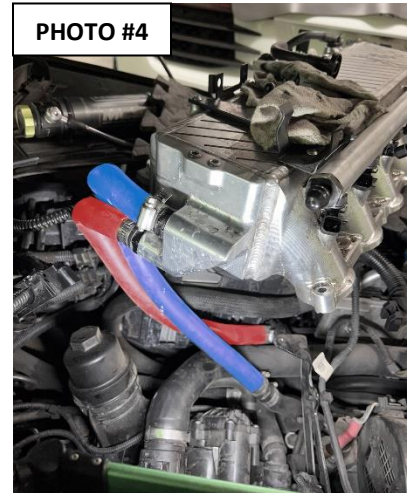

4. Some users have suggested unbolting the wiring harness is located at the back of the manifold and moving to side before installing the manifold (step 5 below), then the harness after the manifold has been set in (see photo #5)



5. Connect flange bolts to cylinder head (See Diagram #1)
 - Start with cylinder 3 first b work outwards from there
 - Qty. 7 bolts (L)
 - Qty. 7 washers (K)
 - Use OEM Torx hardware to bolt down manifold on inlet tank (hardware not supplied b reuse OEM) (see photo #6)

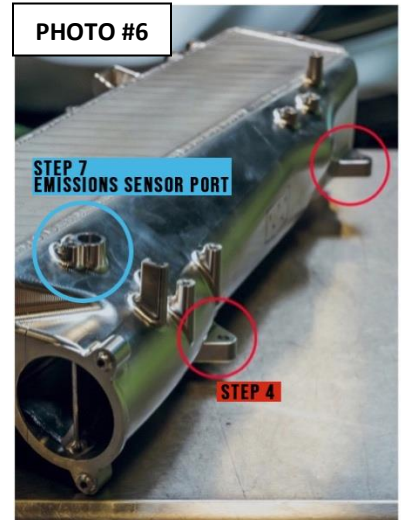

6. Re-install OEM TMAP sensor on outlet tank BEFORE BUILDING OPTIONAL FUEL SYSTEM (See Diagram #1)
 - Qty.1 bolt (AD)
7. Optional b build secondary fuel system (if using rail for top feed port injection) (See Diagram #4)
 - Plumb fuel line feed fitting into rail before attaching rail to manifold

- Install injectors (Qty. 6 not supplied) with injector hats and locking clip into fuel rail
 - Qty. 6 injector hats with locking clips (AA)
 - Insert injectors into manifold
 - Attach fuel rail to manifold
 - Qty. 2 bolts (H) (30mm length)
 - Qty. 2 nuts (D)
 - Qty. 1 bracket (B) (to be installed at the same time)
8. Install brackets to mount engine harness and vacuum lines
- Qty. 1 bracket (J) with Qty. 1 bolt (AF) (located on front water tank b See Diagram #1)
 - Qty. 1 bracket (N) with Qty. 1 bolt (AF) (located on inlet tank b See Diagram #3)
 - Qty. 1 bracket (S) with Qty. 2 bolts (E) (located top rear of inlet tank b See Diagram #3)
 - Qty. 1 bracket (G) with Qty. 1 bolt (E) (located on top front of outlet tank b See Diagram #4)
 - Qty. 1 bracket (B) with Qty. 1 bolt (H) (12mm length) b only used if not installing optional fuel rail (See Diagram #4)
 - Put vacuum canister in bracket before installing
 - Qty. 1 bracket (Q)
 - Qty. 1 bolt (E)
 - Qty. 1 bolt (AE) (shared with bracket (R) b See Diagram #3 / review optional step 8 below before tightening)
 - Reconnect OEM emissions sensor with Qty. 1 bolt (AE) (located on top front of inlet tank b see blue circled area in photo #6 above)
 - OR option to install Qty. 1 fitting (AC), Qty. 1 o-ring (AG), Qty. 1 bolt (AE) (See Diagram #3) (used to block-off sensor port if not desired)
9. Install optional brackets for installing engine cover. These will not install if fuel rail is installed. (See Diagram #3)
- Qty. 1 post (P) with Qty. 1 bolt (AF) inserted into bracket (R)
 - Qty. 1 bracket (R) with Qty. 1 bolt (E) and shared bolt (AE)
 - Bracket (R) orientation is specific. Please refer to diagram for shape (long side towards inlet tank).
 - Qty. 1 post (O)
10. Bleeder screws in the back to bleed air out of the system (See Diagram #3)
- Located at the rear of the manifold, on top of the back water tank
 - Qty. 2 1/8" NPT plugs (T)
 - Do not use permanent sealant as these may be used frequently
 - Follow OEM bleed procedure located in your vehicle's service manual
11. Install engine cover if desired (will not fit if fuel rail is installed unless engine cover is modified to fit)
12. Optional fittings included

- Qty. 1 fitting (AC), Qty. 1 o-ring (AG), Qty. 1 bolt (AE) (See Diagram #3)
 - Used to block-off sensor port if not desired
- Qty. 1 Crankcase Hose Fitting (AJ), Qty. 1 o-ring pre-installed (AM) (See Diagram #1)
 - Used to connect to OEM crankcase vent tube
- Qty. 1 Crankcase Bung Fitting (AK), Qty. 1 o-ring pre-installed (See Diagram #1)
 - Used to cap-off crankcase vacuum source if OEM crankcase vent tube is unused

DISCLAIMER!

This installation involves working on fuel systems and it is not advised for the inexperienced DIY person. Before commencing installation, ensure you have technical information on replacement process or seek skilled/professional assistance. Always follow national safety standards for working on flammable liquids and health and safety laws. CSF is not responsible for incorrectly fitted parts or consequential loss and/or damages. The installer is responsible for using their own discretion to determine their level of ability, not CSF. Always use appropriately rated safety goggles and use fans to ventilate working space and avoid fume inhalation.

***Installing high flow rate fuel injectors may cause the dashboard instrument cluster fuel consumption and remaining mileage (TRIP) calculations to be incorrect.

CSF pressure tests each #8200 / #8200C manifold at 60-70 PSI for a period of 2-3 minutes during the Quality Control and Inspection process. The CSF manifold is not designed to operate above 60 PSI. Any users who chose to operate their vehicle with the CSF manifold over 60 PSI does so at their own risk. Operation at these pressure levels will void the CSF Limited Lifetime Warranty.

Motor racing is extremely hazardous, and death may occur. CSF products have no warranty or representations made with ability to protect against injury or death. Motor racing, aggressive driving, including driving for any period of time at full throttle, and car modifications of any kind that facilitate aggressive driving may reduce the useful life of the car and or any of its wearable parts. Improving the performance of an engine by altering the engine's computer software may cause the engine to "work harder" and could result in damage to the car. The user assumes these risks.

QUESTIONS?

CONTACT US AT INFO@CSFRACE.COM

THIS PRODUCT IS DESIGNED SOLELY FOR OFF-ROAD OR MOTORSPORTS USE.

I M P O R T A N T !

H O W T O R E C I E V E Y O U R F R E E L I M I T E D E D I T I O N C S F T - S H I R T

HOW IT WORKS:

In order to do our part in saving the environment and avoiding unnecessary waste as well as keeping costs down, which has been passed through to the end consumer, if any of the following items are not used in your vehicle, please send them back to CSF using the supplied envelope with pre-paid postage. If you are an international customer, please contact us at info@csfrace.com

OPTION #1 - FOR VEHICLES NOT USING THE SECONDARY FUEL SYSTEM AND/OR PORT INJECTION

- Qty. 6 injector hats with locking clips (AA)
- Qty. 1 hex plug (AB)

OPTION #2 - FOR VEHICLES USING THE SECONDARY PORT INJECTION SYSTEM

- Qty. 6 injector port bungs (F)
- Qty. 1 post (O)
- Qty. 1 post (P)
- Qty. 1 bracket (R)

ADDITIONAL PARTS FOR RETURN

Also, if any of the following parts are not used, please return them as well:

- Qty. 1 emission port cap (AC)
- Qty. 1 Crankcase Quick Connect Hose Fitting (AJ) or Crankcase Bung Fitting (AK)

Along with any and all bolts, nuts, washers, or other brackets not used during installation.

**I F Y O U H A V E A N Y Q U E S T I O N S I N R E G A R D S T O T H I S R E T U R N P R O C E S S O R
I F Y O U A R E A N I N T E R N A T I O N A L C U S T O M E R ,
C O N T A C T U S A T [I N F O @ C S F R A C E . C O M](mailto:info@csfrace.com)**

**Q U E S T I O N S ?
C O N T A C T U S A T [I N F O @ C S F R A C E . C O M](mailto:info@csfrace.com)**

THIS PRODUCT IS DESIGNED SOLELY FOR OFF-ROAD OR MOTORSPORTS USE.