



INSTALLATION GUIDE: AWE AXLE-BACK EXHAUST SUITE FOR THE CAMARO SS/ZL1

For up-to-date fitment information, please visit the product page on AWE-Tuning.com.

THIS GUIDE IS INTENDED FOR THE FOLLOWING PART NUMBERS:

- 3020-32049 AWE Track Edition Axle-back Exhaust for Gen6 Camaro SS - Chrome Silver Tips (Dual Outlet)
- 3020-33053 AWE Track Edition Axle-back Exhaust for Gen6 Camaro SS - Diamond Black Tips (Dual Outlet)
- 3015-32103 AWE Touring Edition Axle-back Exhaust for Gen6 Camaro SS - Chrome Silver Tips (Dual Outlet)
- 3015-33103 AWE Touring Edition Axle-back Exhaust for Gen6 Camaro SS - Diamond Black Tips (Dual Outlet)
- 3020-42067 AWE Track Edition Axle-back Exhaust for Gen6 Camaro SS / ZL1 - Chrome Silver Tips (Quad Outlet)
- 3020-43075 AWE Track Edition Axle-back Exhaust for Gen6 Camaro SS / ZL1 - Diamond Black Tips (Quad Outlet)
- 3015-42093 AWE Touring Edition Axle-back Exhaust for Gen6 Camaro SS / ZL1 - Chrome Silver Tips (Quad Outlet)
- 3015-43115 AWE Touring Edition Axle-back Exhaust for Gen6 Camaro SS / ZL1 - Diamond Black Tips (Quad Outlet)

Welcome to the AWE family, and congratulations on your purchase of the AWE Exhaust System for the Camaro SS/ZL1.

Exquisite build quality and craftsmanship, coupled with industry leading performance, distinguish this exhaust system from all others.

*For up to the minute fitment information, be sure to visit the AWE website. As always, AWE Performance Specialists are standing by for any questions, [right here](#).

PARTS LIST



INSPECT ALL PARTS PRIOR TO DISASSEMBLY OF VEHICLE; IF DAMAGED OR MISSING, PLEASE CONTACT THE PLACE OF PURCHASE IMMEDIATELY.

Touring Edition Parts: (NPP Only)

- 1 180Technology® rear section - driver (*part B18*)
- 1 180Technology® rear section - pass. (*part B19*)

Track Edition Parts: (NPP Only)

- 1 Tailpipe section - driver (*part B16*)
- 1 Tailpipe section - pass. (*part B17*)

Hardware Kit: (NPP Only)

- 4 4.5" slash-cut tips (*optional finish*)
- 2 2.75" to 3.0" Inlet adapters
- 2 3.0" Accu-Seal clamps
- 4 3.0" Tip clamps

Touring Edition Parts: (non-NPP Only)

- 1 180Technology® rear section - driver (*part B24*)
- 1 180Technology® rear section - pass. (*part B25*)

Track Edition Parts: (non-NPP Only)

- 1 Tailpipe section - driver (*part B22*)
- 1 Tailpipe section - pass. (*part B23*)

Hardware Kit: (non-NPP Only)

- 2 4.5" slash-cut tips (*optional finish*)
- 2 2.75" to 3.0" Inlet adapters
- 2 3.0" Accu-Seal clamps
- 2 3.0" Tip clamps



PRO-TIP: Installation of any exhaust should be performed by an experienced professional with the necessary equipment and know-how to effectively complete the install.

NPP LAYOUT:

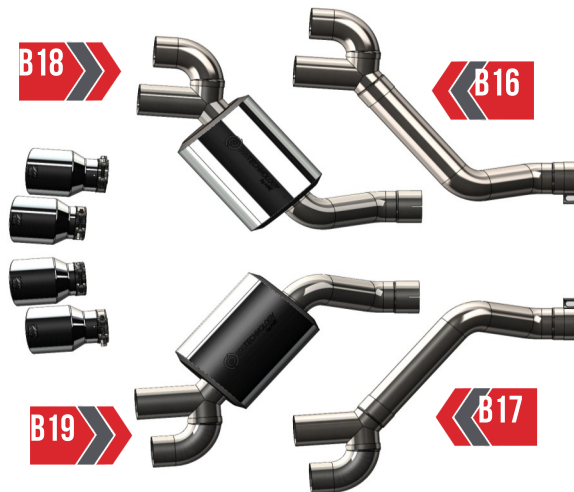

NON-NPP LAYOUT:

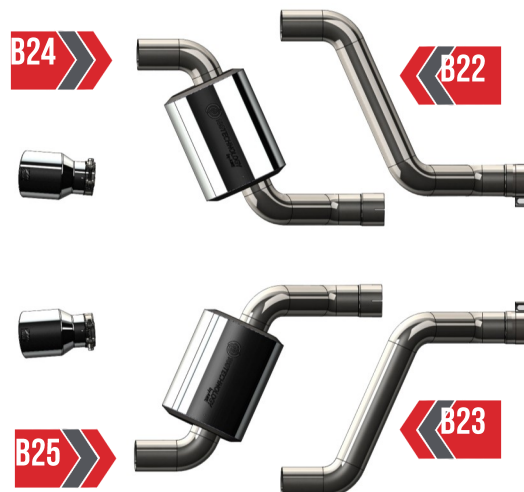

STEP 1



The factory exhaust must be **CUT** from the car to install the AWE Performance Exhaust System. Reinstalling the factory exhaust will require the use of a sleeve clamp.



Always refer to the manufacturer service manual for precise torque specifications on all OEM fasteners.



WARNING: Allow the exhaust ample time to cool; serious injury and burns can occur if handled at operating temperature.

NPP Equipped Only:

Locate and unplug the factory valve control harnesses from the factory valve control motors, driver side location shown by the arrow in **Figure 1**,

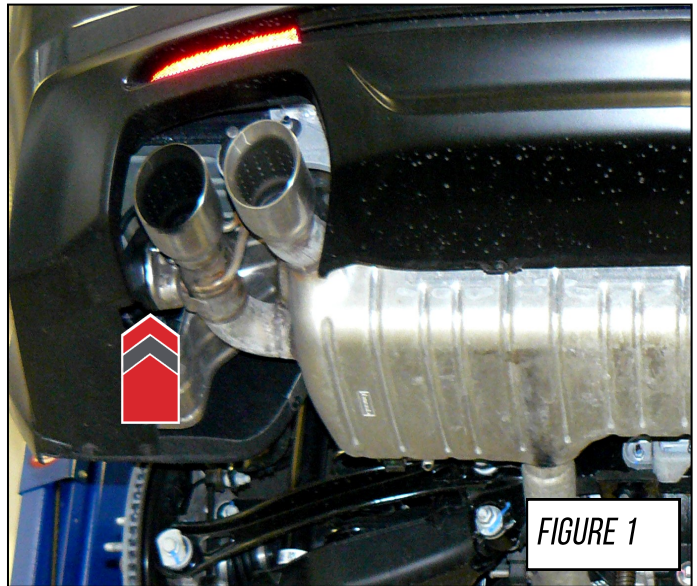

STEP 2



NOTE: Prior to exhaust removal, be sure the system is properly supported with pole jacks or recruit an extra set of hands to help.

Locate and spray the factory hanger bracket bolts with a penetrant oil to assist in removal, location shown by

Arrows A in **Figure 2**.

Spray the hanger post and bushing with the same penetrant, location shown by **Arrows B** in **Figure 2**.

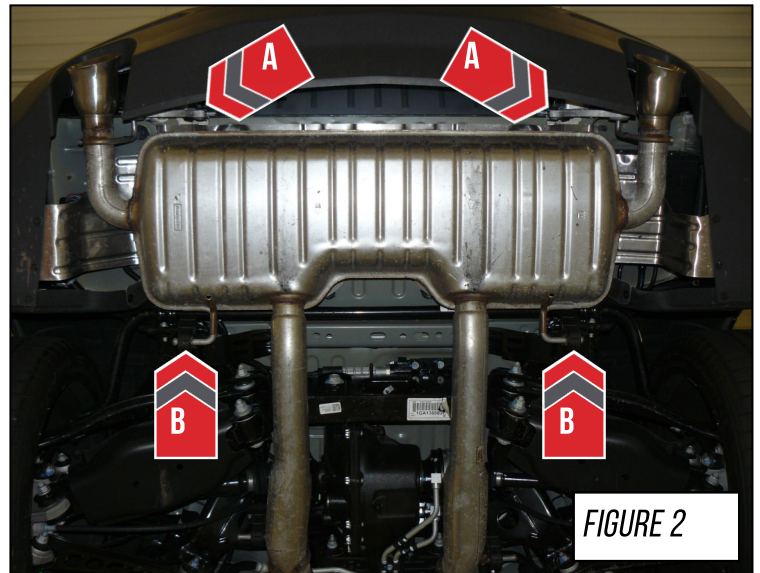

STEP 3

Marking & Cutting the Factory Exhaust:

PRO-TIPS:



- Use a metal-cutting saw or a chain-style pipe cutter to make the cuts outlined below.
- Masking tape can help provide a guide to make a straight cut.

The line, called out by **Arrow A** in **Figure 3-1**, marks the back edge of the rear cross-member on the car; measurements given are off this point.

Measure 2-inches back (towards the rear of the car) from the cross-member, marking with tape or a marker, as shown by **Arrows B** in **Figure 3-1**.

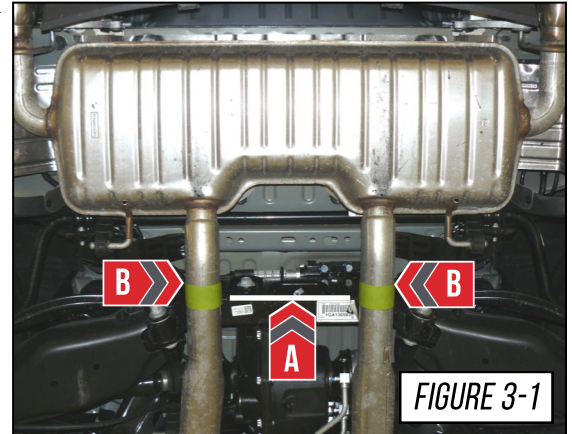

FIGURE 3-1

Using a ruler as a straight-edge off the back side of the cross-member is the best way to translate the measurement, shown by the arrow in **Figure 3-2**.

Make sure the ruler is parallel with the back face of the cross-member.

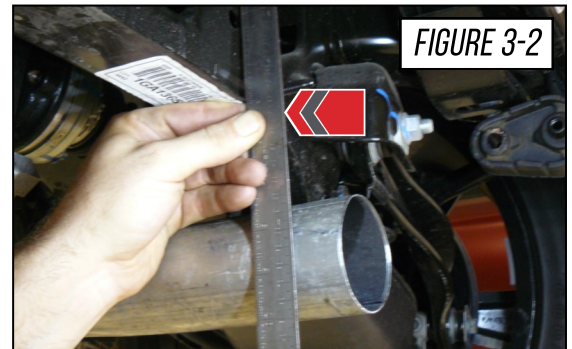

FIGURE 3-2

The arrow in **Figure 3-3** shows how two rulers can be used to get the correct marking for cutting the rear muffler section off of the factory exhaust system.

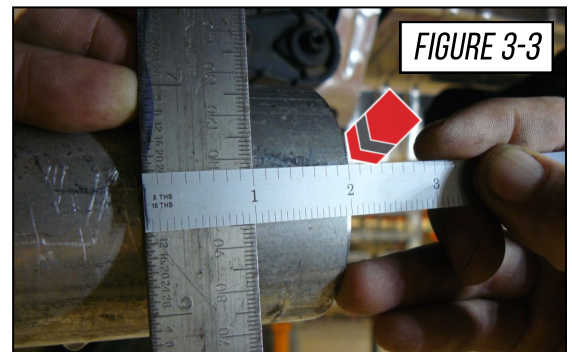

FIGURE 3-3

STEP 4

Remove the brackets and separate the bushings that were called out in *Step 2*, this will allow the rear muffler section to be removed from the vehicle.



NOTE: Use a pole-jack or another person to help remove the rear muffler.

Deburr the cut ends of the factory exhaust system, shown by the arrows in **Figure 4**.

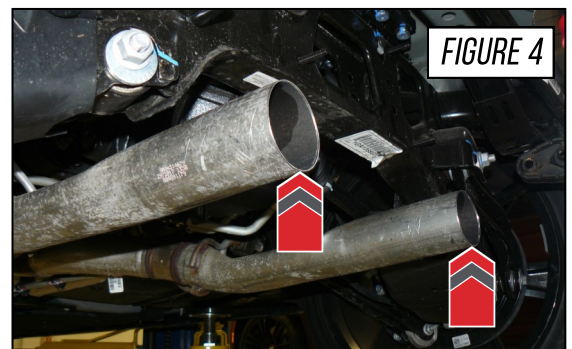

FIGURE 4

STEP 5

Installing the AWE Performance Axle-back System:

Slide the two (2) included adapters over the factory exhaust outlets, as shown by the arrows in **Figure 5**.

Slide them approximately 2.5-inches from the end of the tubes.



NOTE: The goal is to have the adapter line-up with the inlet edge of the AWE Exhaust System.

For NPP installations:

Before installing the tailpipe sections, use an electrical tape to seal the open ends of the valve motor harnesses that were disconnected in *Step 1*.

Secure each harness up and out of the path of potential hot exhaust components or moisture.

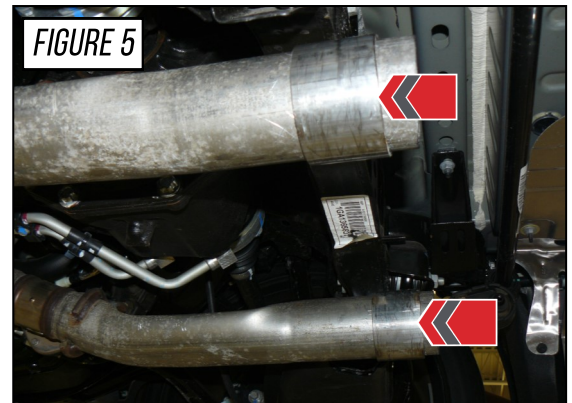

STEP 6

Place the included 3.0" Accu-Seal clamp over the driver side tailpipe section (part B16, B18, B22 or B24) and install onto the corresponding outlet from the factory exhaust, as shown by **Arrow A** in **Figure 6**.

As the tube slides over the adapter, hold it in place, as shown by **Arrow B** in **Figure 6**.

Place the final 3.0" Accu-Seal clamp over the inlet side of the passenger side tailpipe section (part B17, B19, B23 or B24) and repeat the previous steps taken for the driver side.

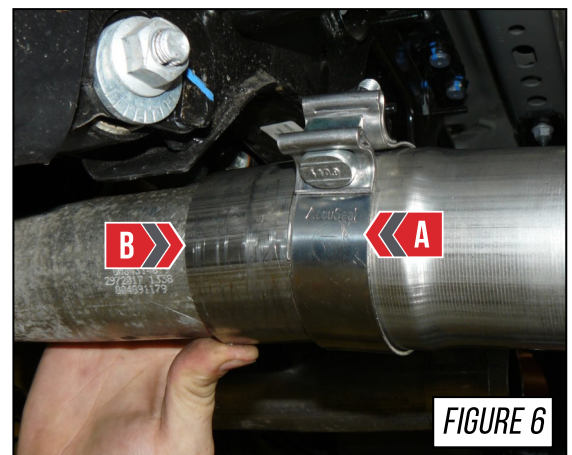

STEP 7

Transfer the hanger brackets from the factory muffler to the corresponding AWE Tailpipe Sections, as shown by the arrow in **Figure 7**.



NOTE: The factory hanger brackets are driver and passenger side specific, mixing them up will cause a fitment issue.



STEP 8

Reinstall the factory nuts to secure the hanger brackets into the original location, driver side shown by the arrow in **Figure 8**.

Torque to factory specification.

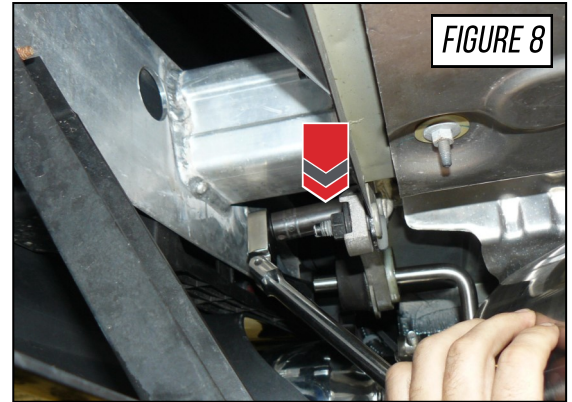

FIGURE 8

STEP 9

Insert the hanger bar, shown by **Arrow A** in **Figure 9**, into the factory hanger bushing shown by **Arrow B**.

Using a hammer with a center-punch or a flathead screwdriver, tap the adapter flush into the inlet end of the AWE Performance Exhaust, location shown by **Arrow C** in **Figure 9**.

Repeat for passenger side.

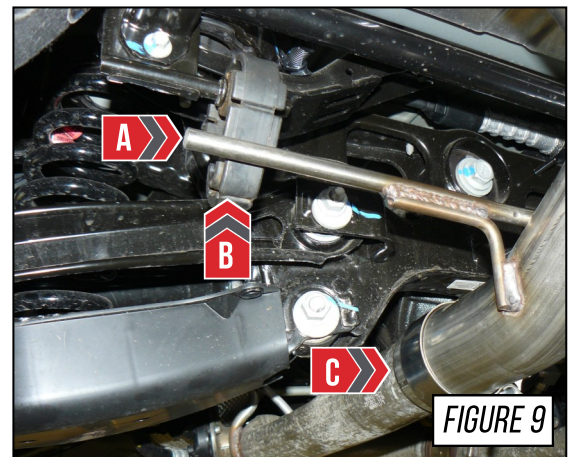

FIGURE 9

STEP 10

It is crucial to install each section and Accu-Seal clamp correctly to prevent loose joints and exhaust leaks between the tubing connections.

Arrow A in **Figure 10** shows the expanded pipe and the preinstalled Accu-Seal clamp being brought up to the corresponding pipe.

Arrow B in **Figure 10** shows the overlapping pipe installed correctly over the corresponding pipe.

Arrow C in **Figure 10** shows the Accu-Seal clamp being brought to the edge of the expanded pipe.

NOTES:



- Do not torque any Accu-Seal clamp until the entire exhaust has been installed and adjusted.
- Torque specification is a minimum of 40 ft/lbs.

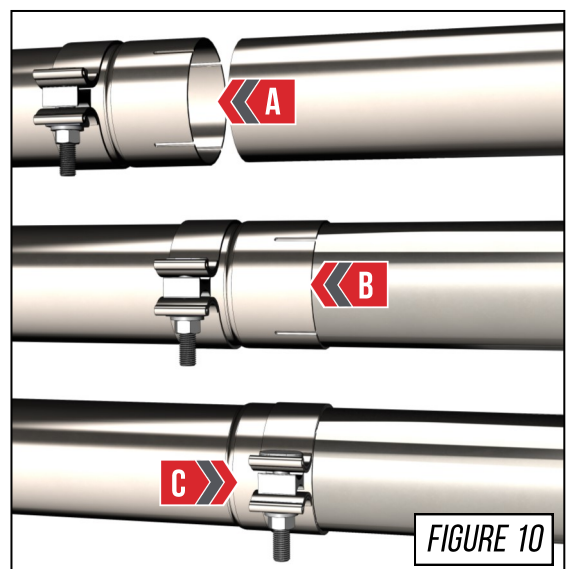

FIGURE 10

STEP 11

To install the exhaust tips with integrated clamps, first, attach the exhaust tip in the proper orientation onto the exhaust outlet tube.

Insert one of the carriage bolts from the hardware kit (**3910-41010**) through the tab on the exhaust tip and thread on one of the corresponding nuts.

Using anti-seize on the bolt threads will help installation and prevent breakage of hardware.



If exhaust system only has 2 exhaust tips while the integrated clamp kit has enough hardware for our 4 tip exhaust systems. You will have 2 sets of hardware left over that will not be used.

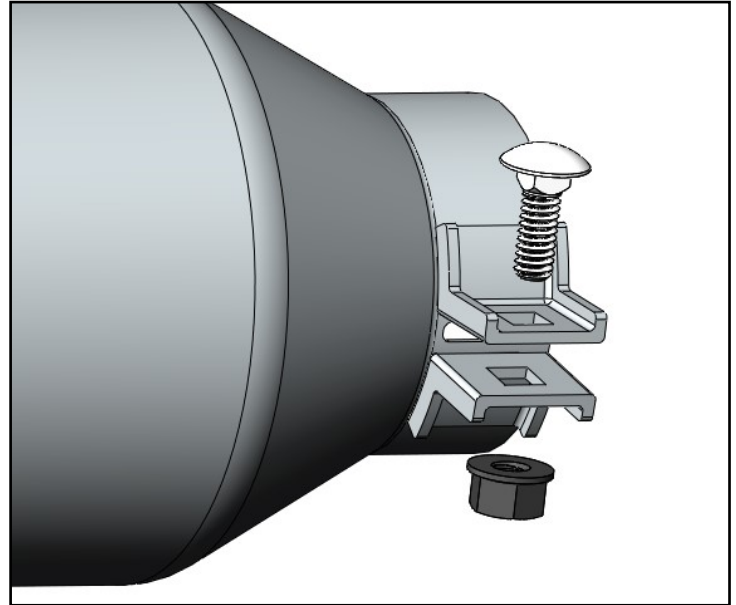

STEP 12

Using the integrated clamp kit, install the 4.5" slash-cut tips as shown in **Figure 12**.

Do not torque the clamps until completely satisfied with placement.



STEP 13

Once tip and tailpipe alignment is satisfactory, torque the Accu-Seal clamps to specification, followed by the tip clamps.

Installation is complete!



ENJOY!



TROUBLESHOOTING

Issue	Solution
Exhaust is not fitting correctly	Most fitment issues are due to improperly adjusted exhaust. This includes tip fitments and rattling due to chassis contact. Check out our fitment guide for more installation tips.
Incorrect or missing parts	Double check the parts list for your system and compare them with what you received. Fill out our contact form, found below and let us know what parts you need.

CARE

Once installed properly, your AWE exhaust will provide years of trouble-free performance.

The exhaust volume and sound will settle with usage; 800-1000 miles is required to break-in new exhaust systems.

Also, please note that the rear **180Technology**® resonator has a small drain hole to allow condensation to escape. Water drops from this area are normal.

Periodic cleaning of exhaust tips is necessary to maintain proper finish, especially in areas prone to road salt and caustic deicing solutions. Use a mild soap and water solution or car wax to clean the finish. Avoid using abrasive polishes, as they can scratch the finish.

Any questions or comments,
please do not hesitate to contact us:

AWE
215-658-1670
[CONTACT FORM](#)

WARRANTY

Up-to-date warranty information is found [HERE](#).