



Part number SP1470  
2002-06 Acura RSX 4 Cyl.

- 1- One piece cold air intake
- 1- **3" Dyno-Tuned Filter** (#1017)
- 1- 2 3/4" 90 deg. elbow (#3060)  
w/ 1525 grommet
- 1- 20" 8mm vacuum hose (#3091)
- 1- 18" 15.9mm vacuum hose (#3080)
- 2- Power-Band (.312) (.040) (#4003)
- 1- RSX Long Vibra-mount (#6029)
- 1- M6 flange nut (#6002)
- 1- fender washer (#6010)
- 1- **Custom roto-molded windshield reservoir tank (Part# 6027)**
- 2- m6 x m25 bolts (for reservoir tank) (#6006)
- 2- fender washers (for reservoir tank) (#6010)
- 1- Instruction

Note: This intake system was specifically designed and tested with this filter element.  
Buy replacement parts on-line at **"injenonline.com"**

**Congratulations! You have just purchased the best engineered, dyno-proven cold air intake system available.**

Report any defective or missing parts to the Authorized Injen Technology dealer you purchased this product from. Before installing any parts of this system, please read the instructions thoroughly. If you have any questions regarding installation please contact the dealer you purchased this product from. Installation DOES require some mechanical skills. A qualified mechanic is always recommended.

\*Do not attempt to install the intake system while the engine is hot. The installation may require removal of radiator fluid line that may be hot.

Injen Technology offers a limited lifetime warranty to the original purchaser against defects in materials and workmanship. Warranty claims must be handled through the dealer from which the item was purchased.

Injen Technology 244 Pioneer Place Pomona, CA 91768 USA

**Please check the contents of this box immediately.**

**Note: This intake system was Dyno-tested with an Injen filter and Injen parts the use of any other filter or part will void the warranty and CARB exemption number.**

Parts and accessories are available on-line at "Injenonline.com".

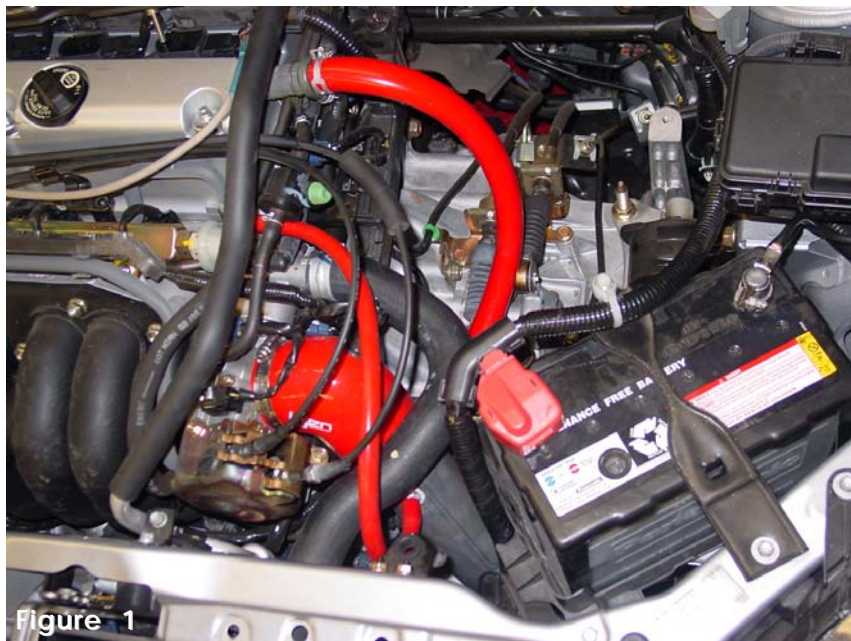

Figure 1

Now available, Hydro Shield by Injen  
Part Number X-1035



Hydro Shield Sold Separately

A ▶ : Screw, 2    B ▶ : Screw, 4    C ▷ : Clip, 10    D ▷ : Clip, 2    <<<< Arrows indicate where fasteners are located

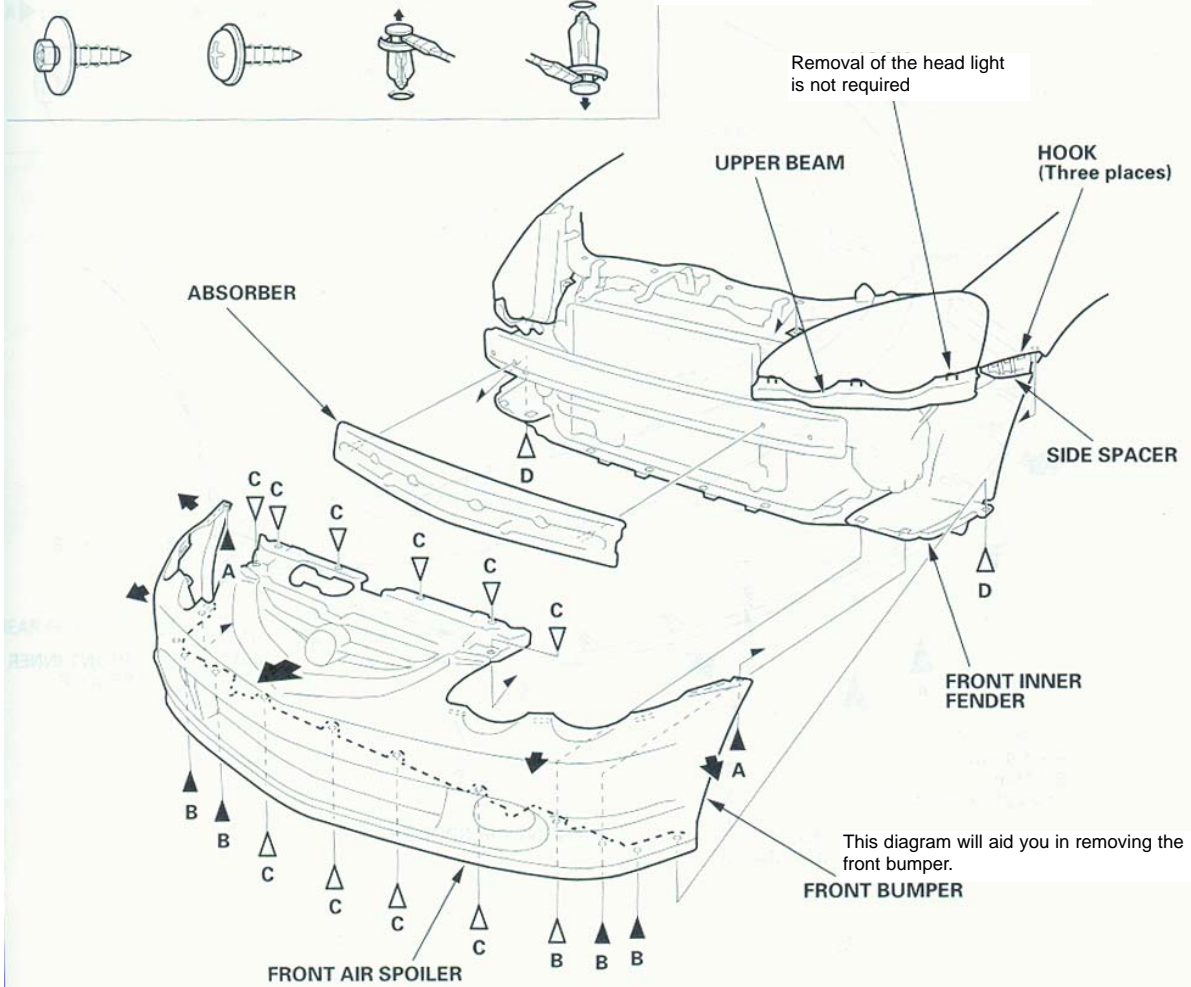

Diagram 1

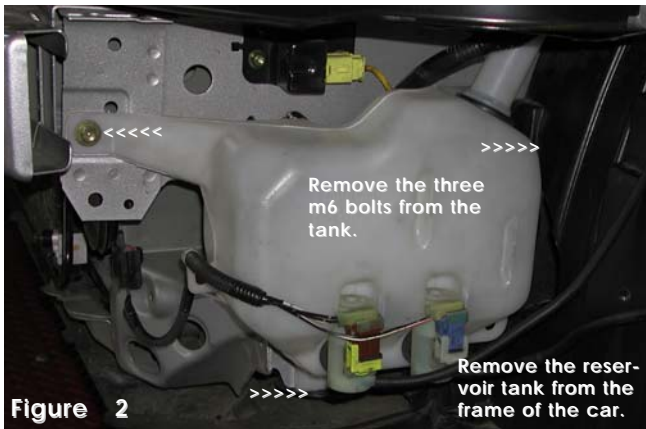

Figure 2



Figure 3

Washer reservoir removal

(A) remove the 2 pin connectors and (B) washer tubes.

Remove the front washer motor >>>

Remove the rear washer motor >>>

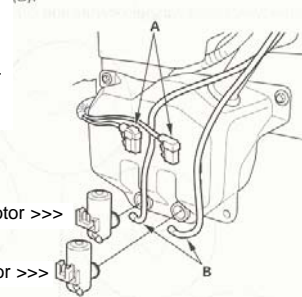

3. Remove the four bolts and washer reservoir (A).  
(C) Remove the 3 m6 bolts in order to remove the reservoir tank.

Use 7.0 lbs.-ft. of torque when replacing m6 bolts.

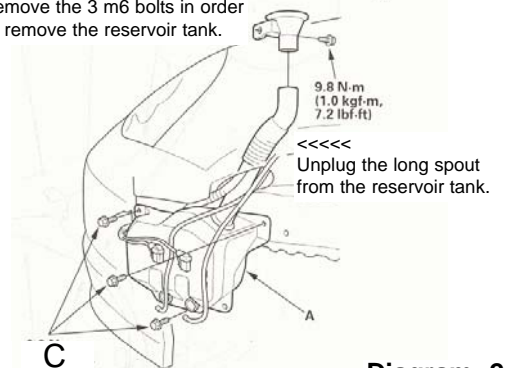
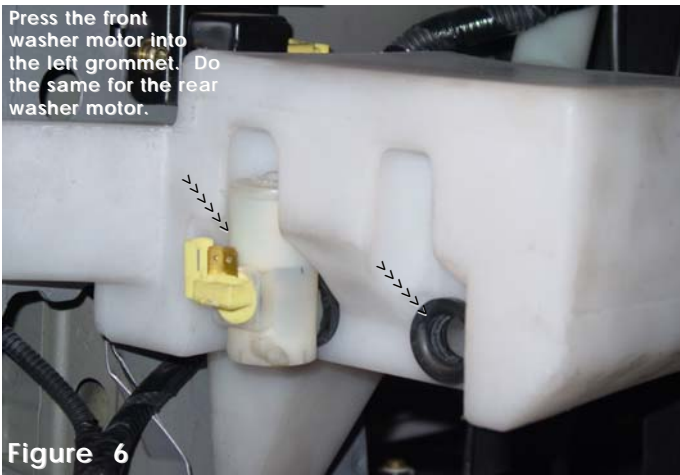
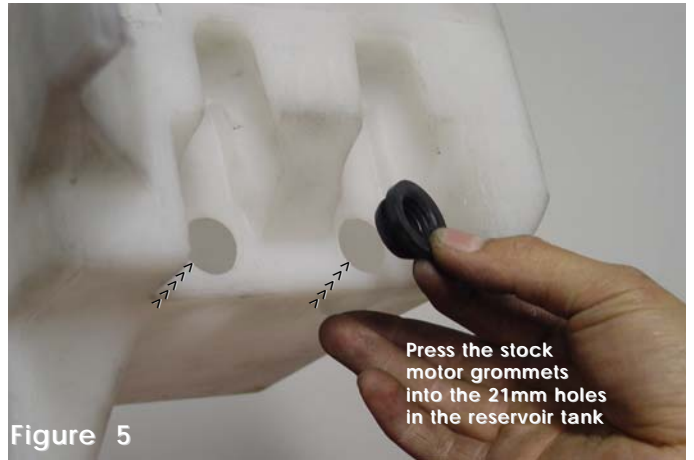
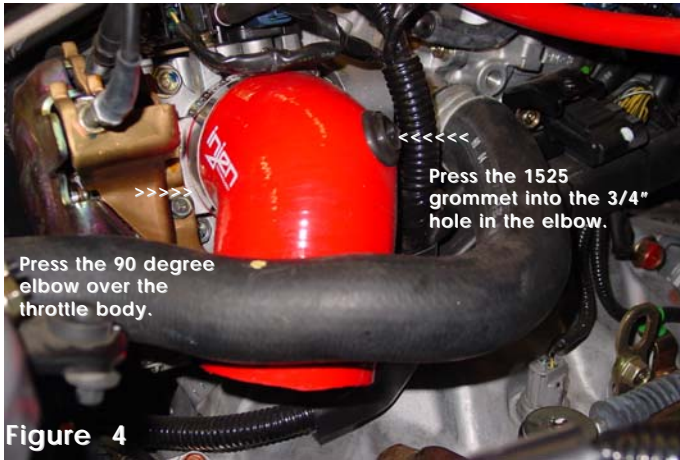
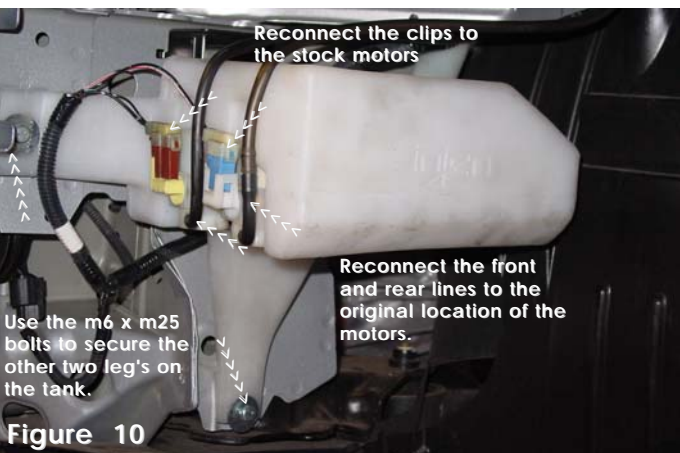
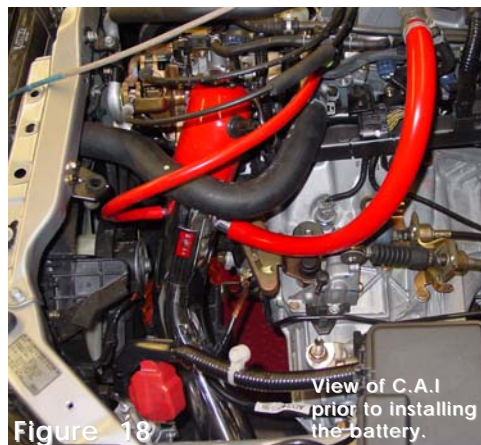
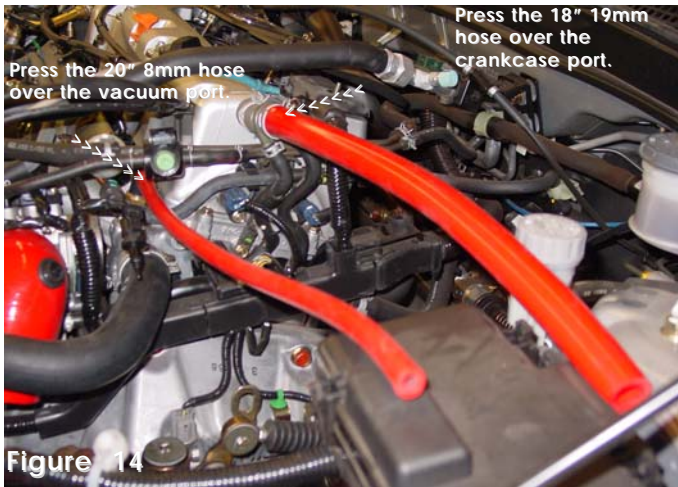
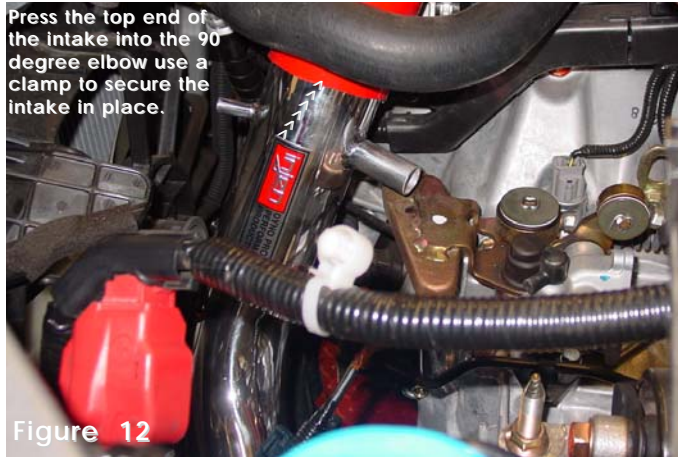

Diagram 2



**Note:** It is extremely important that you hand tighten the m6 x m25 bolts and vibra-mount used to fasten the reservoir tank. Hand tighten bolt and then turn 1/4 turn or 7.0 lbs.-ft. of torque. Too much torque will damage and cause the tank to leak.





**Note: Removal of the entire battery and battery tray will be required for this installation.**

1. Tools required to remove the front bumper are: a flathead screwdriver, phillips screwdriver and a ratchet with an m10 socket. Once tools have been gathered proceed in removing the front bumper. (See Diagram 1)
2. Remove the battery and battery tray from its present location prior to installing the cold air intake.
3. **Removing the windshield washer reservoir-** (A and B) Unplug the connector clip and tube from the front washer motor and the rear washer motor. (C) Unbolt the three m6 bolts holding the reservoir tank to the frame. (See Diagram 2) and (Figure 2)
4. Cut a 4" x 5" opening on both sides of the wheel well splash guard. Slip the cold air intake in and out of the opening to determine the best size opening. A utility knife or cardboard cutter will be required. (See fig. 3)
5. Take the 90 degree elbow and the 1525 grommet. Press the grommet into the 3/4" hole in the elbow. Press the 90 degree elbow over the throttle body and use a small clamp to secure the elbow. (See fig. 4)
6. Remove the washer motor grommets from the stock tank, press them into the 21mm hole in the new reservoir tank. Take the stock washer motors and press them into the grommets on the reservoir tank. (See fig. 6) and (Diagram 2)
7. Press the the large stock grommet into the 36.5mm hole on top of the reservoir tank. (See fig. 7)
8. Prior to securing the tank to the frame of the car press the end of the spout into the large grommet. (See fig. 8)
9. Match the hole pattern to the pre-tapped holes on the frame and screw the vibra-mount into one of the mounting leg's on the tank. (See fig. 9)
10. Take the two m6 x m25 bolts in this kit and screw them into the two other matching holes on the tank. (See fig. 10)
11. Take the tube coming from the front windshield washer and plug it into the front washer motor on the tank. Do the same for the rear windshield washer plug it into the rear washer motor. (See diagram 2 and figure 10)
12. Press the two pin connectors in the bumper area to its respective washer motor plugs. Pins are self mating so they can only fit one way. (See fig. 10)  
**Installing the cold air intake:**
13. Install the cold air intake through the opening in the wheel well made earlier. Insert the top end of the intake with the inlet ports into the opening and gently slide the intake up through the hole and into the 2.75" end of the silicone elbow on the throttle body. Use a small clamp in this kit to secure the intake to the 90 degree elbow. (See figs. 11 and 12)
14. Align the bracket on the lower section of the intake to the vibra-mount stud. Use the m6 nut and fender washer to fasten the intake to the vibra-mount semi-tighten at this point. (See fig. 13) Take the Injen filter and press it over the end of the intake and tighten the clamp on the filter at this point. (See fig. 17)
15. Locate the air temperature sensor and press the sensor into the 1525 sensor grommet. (See fig. 15)  
**Removing and replacing vacuum lines:**
16. **Note:** The plastic port is extremely fragile so **gently** remove the short stock vacuum hose on the "T" fitting. (See fig. 14) Take the 20"- 8mm hose and press one end over the vacuum port and the other over the 3/8" nipple on the intake. Now do the same with the 18"- 19mm hose press one end over the crankcase port and the other end over the 3/4" nipple on the intake. (See figs. 14 and 16 )
17. Carefully align the cold air intake and washer reservoir for best fit. Once proper clearance has been made throughout the length of the intake and the washer reservoir continue to tighten all nuts, bolts and clamps. (See figs. 1 and 18)
18. Replace the battery tray and battery. (See fig. 1)
19. Replace the front bumper to its stock position. (Reverse of diagram 1.)
20. Remove all tools and rags from the engine compartment prior to starting the engine.
21. Congratulations! You have just completed the installation.